

PM.0202
THE INDUSTRIAL CABLE PULLING MACHINE
USER MANUAL



Read and understand all instructions and safety information
in this manual before operating or servicing this tool.

PM.0202

The Industrial Cable Pulling Machine User Manual

Index

1- GENERAL INFORMATIONS AND INSTRUCTIONS	1
1.1. MANUFACTURER	1
1.2. PRODUCT DESCRIPTION AND AREAS OF USAGE	1
1.3. WORKING QUALITY	1
1.4. TECHNICAL PROPERTIES	1
1.5 GENERAL INSTRUCTIONS	2
1.6 GENERAL INSTRUCTIONS FOR THE OPERATOR OF THE INDUSTRIAL CABLE PULLING MACHINE	2
1.7 GENERAL INSTRUCTIONS FOR THE MAINTENANCE OPERATOR OF THE INDUSTRIAL CABLE PULLING MACHINE	3
1.8. INFORMATION AND INSTRUCTIONS ABOUT THIS USER MANUAL	3
1.9. MANUFACTURER'S RESPONSIBILITY	3
2. TRANSPORTATION, PLACEMENT AND INSTALLATION	4
2.1. LIFTING AND TRANSPORTING THE MACHINE	5
2.2. TRANSPORTATION	5
2.4. UNPACKING	5
2.5. ENVIRONMENTAL FACTORS	6
2.6. PLACING AND FIXING	6
3. OPERATING INSTRUCTIONS	6
3.1 INSTRUCTIONS FOR THE OPERATOR	6
3.2 OPERATING THE MACHINE	6
3.3 PREPERATION	7
3.4 STARTING THE MACHINE	9
3.4.1. <i>RUNNING THE MECHANISM</i>	9
3.4.2. <i>STOPPING THE MECHANISM</i>	9
4. SAFETY MEASURES	9
4.1 EMERGENCY STOP BUTTON	9
4.2 SAFETY MEASURES DURING OPERATION	9
4.1 OTHER POSSIBLE RISKS	10
5. MAINTENANCE AND PERIODIC CONTROLS	10
5.1 PERIODIC CONTROLS	10
5.1.1 DAILY CONTROLS	10
5.1.2 MONTHLY CONTROLS	11
5.1.3 ANNUALS CONTROLS	11
5.2 SPARE PARTS AND AFTER-SALE SUPPORT	11

1- GENERAL INFORMATIONS AND INSTRUCTIONS

1.1. MANUFACTURER

TEMHA Makine Elk. Müh. Pro. San. ve Tic. Ltd. Şti.
Saray Mah. 151. Cad. No:3 Kahramankazan / ANKARA
+90 312 395 83 68
bilgi@temhamakine.com
www.temhamakine.com

Please specify model number, serial number and year of production while requesting information about our products. You can find more info in the section "Product Description and Areas of Usage)

1.2. PRODUCT DESCRIPTION AND AREAS OF USAGE

Industrial Cable Pulling Machines (Model Number: PM.0202) consists of a drum, a gearbox, a benzin motor and chassis. These machines are used for pulling cables with the help of a piece of rope wrapped around the capstan. The capstan is driven by a 4,5kW Benzin Motor.

Speed of the Benzin motor is adjusted by throotle lever

1.3. WORKING QUALITY

Big capstan Maximum Pulling Capacity: 5 kN

Small capstan Maximum Pulling Capacity: 10 kN

Maximum Pulling Speed: 15 m/min



WARNING! Do not use this machine to pull cables for which exceed the capacity of this machine!

1.4. TECHNICAL PROPERTIES

Mass: 105kg

Dimensions (WidthxLengthxHeight): 1000mm x 835mm x750mm

Benzin Motor: 4.5 kW / 3000 RPM

Gearbox Lubricant: DIN 51517-3, [-10 , +40 C].

Benzin oil: 10W-40

Nominal Diameter of the Small Capstan: 91 mm

Max. Load of the Small Capstan: 1000Kg

Nominal Diameter of the Big Capstan: 179 mm

Max. Load of the Big Capstan: 500 Kg

1.5 GENERAL INSTRUCTIONS

a. Only qualified personnel must use the machine. A personnel who has been trained by the user corporation or trained by the manufacturer company is defined as qualified personnel.

b. TEMHA Makine provides training on it's own facilities if requested. Users who chose not to be trained by TEMHA Makine acknowledges the reponsibility against any problems due to using errors and mistakes before hand.

c. Machine can only be used to complete tasks for which it has been designed to do or tasks which has written permission by manufacturer.

d. Machine should not be used by untrained or unauthorized personnel.

e. Please contact the manufacturer in case of any unclarities about using, applying maintenance or any other topic.

1.6 GENERAL INSTRUCTIONS FOR THE OPERATOR OF THE INDUSTRIAL CABLE PULLING MACHINE

a. The operator of machine has the responsibility of following all work safety rules of the country in which they operate the machine.

b. Operators must wear suitable clothes for the job. All necessary precautions must be taken against the loose clothes, necklaces, hoodie wears, unbraded hairs etc. being stuck in moving parts.

c. Using neccesary safet equipments such as work-boots, gloves, barret etc. is the operators responsibility.

d.Operator should never try to fix or change anything on machine which is not under their authorization.

e. Operator must strictly comply with all the danger and warning signs placed on the machine and defined in this user manual.

f. The working are must be cleaned off any unnecessary objects. The area must be checked and cleaned off any liquid residues and thin planar objects like paper, stretch wrap etc.

g. Fitures and anchorages which are necessary for the operation of machines must be done properly, tight, safe and as decrided in this manual.

1.7 GENERAL INSTRUCTIONS FOR THE MAINTENANCE OPERATOR OF THE INDUSTRIAL CABLE PULLING MACHINE

a. Any mechanical adjustments, asemblies and repairs on the machine during a pulling operation is absolutely forbidden.

- b. All maintenance operations must be conducted on a plane surface and in a suitable area. Make sure the machine is not under any load before starting any maintenance operation.
- c. Make sure the machine is disconnected from power-grid and any hot-surfaces are safely cooled down.
- d. Every maintenance operation must be conducted by trained and/or authorized personnel only. A personnel who has been trained by the user corporation or trained by the manufacturer company is defined as qualified personnel.
- e. Maintenance operators must wear suitable clothes for the job. All necessary precautions must be taken against the loose clothes, necklaces, hoodie wears, unbraded hairs etc. being stuck in moving parts.
- f. Maintenance operators have the reponsibility of wearing all the necessary safety equipments such as work gloves, barret and work-boots.

1.8. INFORMATION AND INSTRUCTIONS ABOUT THIS USER MANUAL

- a. Every instrucon, warning and informaon stated in this user manual is for all operators, maintenance operators and field supervisor.
- b. This manual must be read by all operators, maintenance operators and field supervisor before operating the industrial cable pulling machine.
- c. It is field supervisor's responsibility that every warning and instruction on this manual is followed properly by both operators and maintenance operators. Field operator also has the responsibility to make sure every instruction on this manual is applicable.
- d. This manual must be preserved during the machine's life time. All necessary measures should be taken to make this manual is within reach of every operator.
- e. Preserve this document in a dry and protect from environmental conditions.

1.9. MANUFACTURER'S RESPONSIBILITY

Mini industrial cable pulling machine is designed and manufactured for the sole purpose of pulling cables. It is forbidded to use it for other purposes, including purposes which are not stated in this manual.

Responsibility of possible injuries and accidents which might happen due to not following instructions stated in this manual, not using proper safety gear such as barrets, work-boots, gloves etc. or using the machine outside of it's purpose or using the machine wrong belongs to the user.

Manufacturer won't take any responsibility for possible inconveniences should any of the following occur:

- a. Making modifications on the machine without manufacturers written permission and approval.
- b. Using the machine outside of it's sole purpose,
- c. Not using original replacement parts,

- d. Wrong application of maintenance operation,
- e. Augmenting the machine with equipments which are not produced by manufacturer or equipments which are not approved by manufacturer in written,
- f. Not taking personal, general or technical safety precautions,
- g. Not following the instructions stated in this manual properly.

2. TRANSPORTATION, PLACEMENT AND INSTALLATION

2.1. LIFTING AND TRANSPORTING THE MACHINE

- a. Carrying capacities of every system, maximum capacities of anchorage points of these systems and every lifting equipment to be used to carry industrial cable pulling machine can't be smaller than the weight of the machine.
- b. Sizes of the lifting elements such as hooks, ropes etc. must be compatible to anchorage points on the machine.
- c. Fulcrums which are advised by the manufacturer must be used to carry this machine. (Figure 1)
- d. No human allowed to be under or on the machine during the carrying process.

D A N G E R !



Not following the warnings above will not only create dangerous situations and risk safety, but also can damage to the machine in a way that warranty is canceled

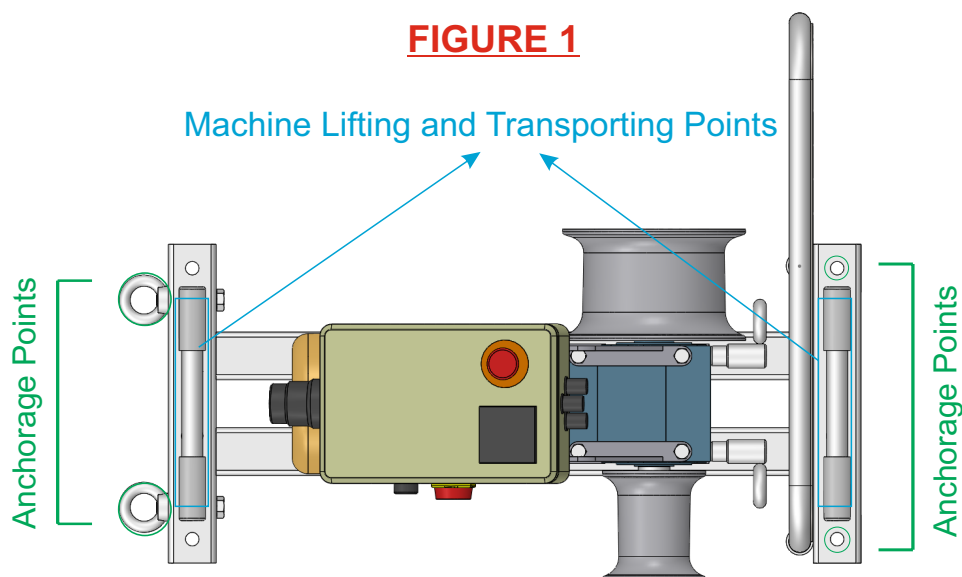

2.2. TRANSPORTATION

- a. All necessary measures should be taken against colliding and tumbling to prevent machine from damaging during naval and land transportation.
- b. Industrial cable pulling machine contains lubricant fluid inside it's gearbox and this case is hermetically enclosed. Necessary precautions must be taken to protect gearbox against colliding and damaging in a way that creates leakage of lubricant.
- c. The packaging materials are generally wood based materials, steel screws and nails, cardboard, paper and multilayered cling wrap.

2.4. UNPACKING

- a. Please check the integrity and general situation of the package as soon as the machine is delivered. Photograph any imperfections that might have happened during transportation and contact cargo company and the manufacturer.
- b. Please make sure the product you have been delivered is the model you ordered. If there is any inconvenience please contact the manufacturer.

2.5. ENVIRONMENTAL FACTORS

Working temperature and humidity of the machine is;

Temperature interval: -10C , +40C (Note: Machine should not be run in full capacity between 40'C -50'C Freezing should be avoided.)

Humidity: Maximum %95 RH (Without condensation.)

2.6. PLACING AND FIXING

- a. Make sure the ground the machine will be placed and the anchor that the machine will be fixed (tree, pole, column, steel construction etc.) is sturdy enough. There shouldn't be any planar objects like paper, cardboard etc. between the machine and ground. Also check and make sure there are no liquid substances on the ground where the machine will be placed. Liquid substances might act as lubricant and can cause safety and operating problems.
- b. The angle between the axis of the drum and the axis of the rope that is fastened to the cable to be pulled must be 90 degrees.. (Figure 2)
- c. After placing properly, the machine must be fixed using 4 anchorage points on the chassis. (Figure 1)
- d. To anchor the machine follow the steps:
 - Place the machine in a way that the drum's axis is vertical to the cable to be pulled.
 - Fasten machine firmly to pre-designated anchorage structure (tree, column etc.) using the anchorage points of machine on the other side of the cable. Make sure the rope and other fastening elements' capacities are over the magnitude of the required pulling forces.
 - Tighten and stretch anchorage ropes using proper equipments.

FIGURE - 2

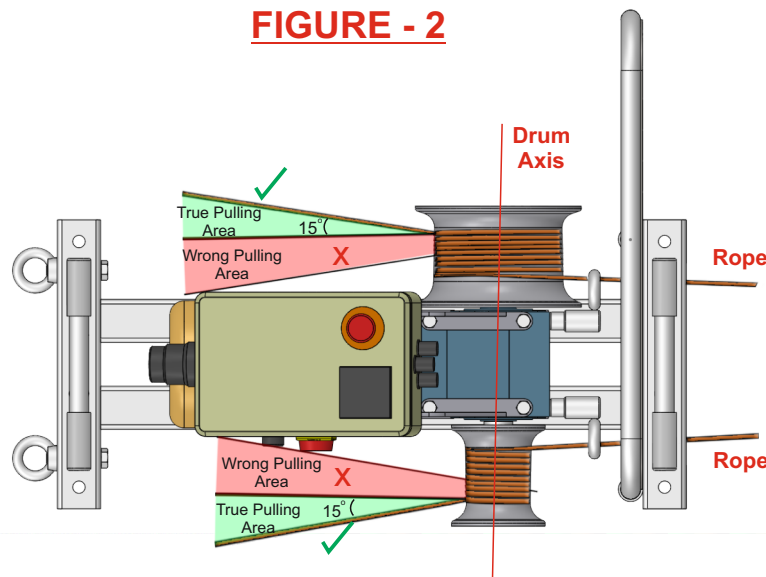

WARNING: Make sure enough coolant air is circulating around the benzin motor's cooling fins. Do not cover these fins during operations and keep your hands clear as it is considered as hot surface.

3. OPERATING INSTRUCTIONS

3.1 INSTRUCTIONS FOR THE OPERATOR

FORBIDDEN: Due to risk of any breaking of anchorages it is strictly forbidden to stand in front or the rear side of machine. Stay at least 5 meters away from the machine if you are not the operator. Please check the following matters daily and before every operation:

Anchorage points of the machine is in good shape, undeformed and safe.

3.2 OPERATING THE MACHINE

Components related to usage of industrial cable pulling machine are shown in [Figure 3,4](#)

On/Off Switch: This switch is used to turn on or turn off the benzin motor.

Emergency Stop Button: This button cuts the power to the machine when pressed.

- PULLING FORCE CONTROL PANEL

This panel is used to set a maximum pulling force value to the machine. The machine will not exceed the magnitude pulling force set through this panel. There are two indicator on the analog clock. The big indicator shows the instantaneous pulling force and the small indicator shows the pulling force limit set by the user. The machine will stop pulling if the value shown on the big indicator becomes equal or larger than the value on the small indicator below momentarily.

Note: To set a maximum pulling force value;

- Press and turn the button which is positioned in the center of analog clock.

Limit value should be decided according to cable's pull-capacity. These values can be found in the cable manufacturer's catalogs.

- ON/OFF SWITCH

This switch is used to turn on or turn off the benzin engine. (Figure 3)

FIGURE - 3

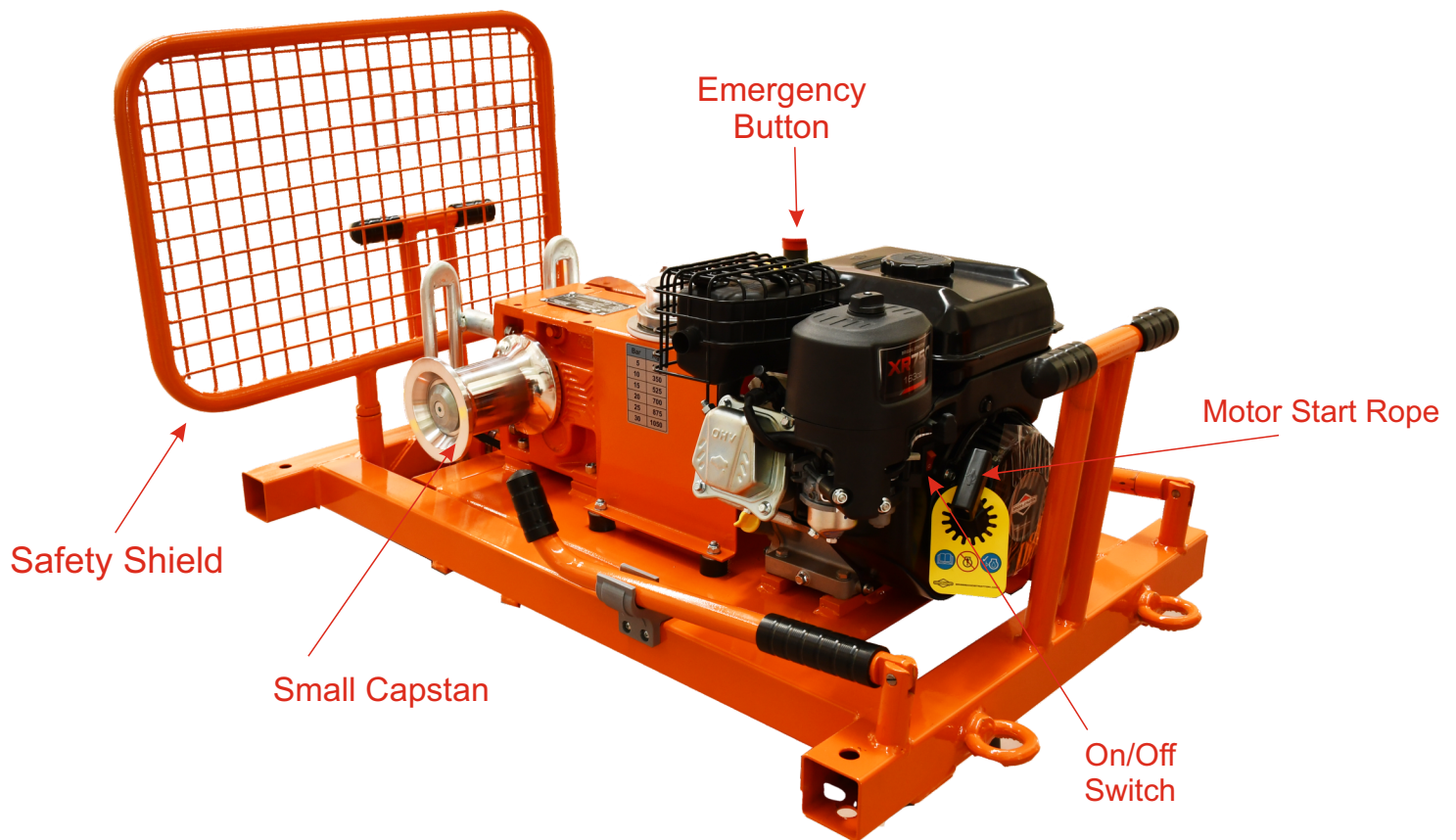

Pulling force limit indicator (small)

Analogue clock for the pulling force control



Current force indicator (big)

FIGURE - 4

- PULLING CAPSTAN (Figure 3)

Used to wrap the rope around to apply pulling operation. These 2 drums have different pulling forces and speeds due to size difference.

- EMERGENCY STOP BUTTON

This button cuts the power to the machine and stops the machine completely when pressed. (Figure 3,4)

3.3 PREPERATION

- a. Load the pulling rope to the drum as shown in Figure 2 Make sure the rope is dry and or not soaked in any potential lubricant substances.
- b. Fasten the pulling end of the cable to the cable grip's ring with a swivel. Make sure it won't loosens under heavy loads.
- c. Fasten the cable side of the cable grip to the cable tight and secure.



DANGER: The load capacity of the fastening technique which is used to fasten the rope to the cable must be equal or larger than the working load of the machine. This fastening method must be as such that it won't come loose under mechanical loads.If this method is not selected carefully and cautiously the rope might get loose and this can cause accidents and injuries.



WARNING: Make sure the motor is turned off and there is no load on the machine while preparing the machine for using.



DANGER: Be careful not to jam your hands to the drum during this process.

3.4. STARTING THE MACHINE



Insert the safety shield according to which drum is going to be used before starting the pulling operation. Do not use the machine without shield in order to prevent accidents that might occur due to failure of rope, cable, swivel or cable grip.

3.4.1. RUNNING THE MECHANISM

- a. Check all the connections, fastenings and placements before running the mechanism and make sure they are all safe and secure
- b. Pull the engine start rope
- c. Load the pulling rope on the capstan.
- d. During the pulling process any personnel who is unrelated to the process should be at least 5 meters away from the machine. The operator should be at least 2 meters away from the machine. The operator also must stay 15 degrees angle to the pulling axis. (Figure 2)

3.4.2. STOPPING THE MECHANISM

- a. Turn off the benzine engine on/off button
- b. If the Emergency Stop Button is pressed, the mechanism stops no matter what.

4. SAFETY MEASURES

4.1 EMERGENCY STOP BUTTON

The machine is equipped with an emergency stop button which stops the machine completely. This button cuts the benzine motor power of machine when pressed.



WARNING: This button should only be used in emergency situations only.

4.2 SAFETY MEASURES DURING OPERATION

- a. Operator has to wear safety gears like protective gloves, barret and safety goggles during the cable pulling operation. Making sure these equipments are being used properly is field supervisor's responsibility.
- b. All fastening points should be checked before operating.
- c. Personnel except the operator should stay at least 5 meters away from the machine.
- d. The operator should never stand behind the machine while pulling. It should stand on the edge with an angle of 15 degrees. (Figure 2)

4.1 OTHER POSSIBLE RISKS

Following risks are possible.

a. Disjuncture of cable or the rope:

- Disjuncture of the rope or cable causes sudden unloading and causes machine to move suddenly. This can creates dangerous situations.

To reduce the probability of this risk:

- Check the ropes before use and change them with new ones if you spot any imperfections.
- Check maintenance section of this manual and follow necessary procedures.

b. Loosening or breaking of fastening points during pulling operation:

- Loosening or breaking of fastening points of unbalances the machine and can cause sudden movements.

To reduce the probability of this risk:

- Check the fastening points periodically and change in case there are any wear or deterioration.
- Follow working positions described in this manual.

c. Entanglement of foreign bodies with drum:

There is no protective covering on drum due to nature of this machine. Operators must be aware so that any unwanted entanglements are avoided.

5. MAINTENANCE AND PERIODIC CONTROLS

5.1 PERIODIC CONTROLS

5.1.1 DAILY CONTROLS

- a. ROPE: Rope must be checked daily and before every use. If any of the following is visible do not use that rope:

- Disintegration on the rope

- Any kind of scratches on the rope ignoring how small it is
- All sorts of wear and frizzles.

Change the rope with a new one if any of these are spotted..

5.1.2 MONTHLY CONTROLS

DRUM: Drum should be checked monthly for if the grinding depth on the drum due to rope forces. If the depth of grooves exceeds 5 millimeters please contact the manufacturer.

5.1.2 ANNUAL CONTROLS

a. **GEARBOX:** Gearbox should be checked annually. Contact the manufacturer if any inconvenience occurs.

Gearbox lubricant must be replaced once in a year.

b. **Benzin Engine Oil:** The oil must be replaced for each 300 hours or once in a year.

c. **Benzin Engine Air Filter:** Air filter must be replaced once in a year.



WARNING: Never run the machine if there is no lubricant oil in the gearbox.

5.2 SPARE PARTS AND AFTER-SALE SUPPORT

Manufacturer will provide the following parts after sale:

- Chassis
- Motor and Gearbox Set,
- Drums
- Control Panel (analogue clock)
- Wheels

Please contact the manufacturer for replacement and spare parts

Contact the manufacturer to order spare parts.



AT UYGUNLUK BEYANI (EC Decleration of Conformity)

İmalatçı Unvanı : TEMHA MAKİNE ELK. MÜH. PRO. SAN. VE TİC. LTD. ŞTİ
Company Name
İmalatçı Adresi : SARAY MAH. 151. CD. NO:3 KAHRAMANKAZAN ANKARA
Company Address
Ürün Tanımı : END. KABLO ÇEKME MAKİNESİ / INDUSTRIAL CABLE PULLER
Product Description
Marka-Model : TEMHA MAKİNE PM.0202
Product Brand-Model
Kapasite : 1000 kg
Capacity
İmal Yılı-Seri No : 2022 - PM.0202.2202
Production Year and Serial Number

Uygulanan Yönetmelikler/ Reference Directive(s)

İmalat ve montajını yaptığımız END. KABLO ÇEKME MAKİNESİ için aşağıdaki direktif / standart koşullarını karşıladığımızı beyan ederiz.

We declare that our INDUSTRIAL CABLE PULLER is manufactured in compliance with below directive / standard

- 2006/42/AT Makine Emniyet Yönetmeliği EK-1
2006/42/AT Machinery Safety Directive Annex -1

Uygulanan Standartlar / Reference Standard(s)

- EN ISO 12100:2010

Teknik Dosyayı Hazırlamakta Yetkili Olan Kişinin Adı ve Adresi

Name and Address of the Person Authorized to Prepare the Technical File

Yusuf KIZILKOCA/ Saray Mah. 151. Cd. No:3 Kahramankazan/ ANKARA

Beyanın Yeri ve Tarihi : Ankara/ 24.01.2022

Decleration Date and Place

İmza Yetkilisi – Ünvanı : Ahmet KIZILKOCA

Authorized Signatory and Title

TEMHA MAKİNE ELEKTRİK MÜHENDİSLİK
PROJE SANAYİ TİC.LTD.ŞTİ.
Saray Mah. 151. Cd. No:3 Kahramankazan/ ANKARA
Tel: (0312) 895 83 80 E-posta: info@temhaink.com
Kahraman Y.D. No:1438928 Tic.Sic.No: 363654
Mersis No: 751179974239878

PM.0202





TEMHA Makine Elk. Müh. Proje San. ve Tic. Ltd. Şti.
Saray Mah. 151. Cad. No:3 Kahramankazan / ANKARA

+90 312 395 83 68

bilgi@temhamakine.com

www.temhamakine.com